

# Height adjustable unit

Controllable measurement  
point displacement **HFM 5**  
Technical information /  
Instruction manual



## Table of contents

---

	Page
Introduction	G2
-----	
Function	G2
-----	
Technical Data	G3
-----	
Electrical connection	G6
-----	
Mounting	G7
-----	
Spare parts	G8

Subject to technical change and price change.

All dimensions in mm (inches).

All units of this information are CE - certified.

We assume no liability for typing errors.

Different variations to those specified are possible.  
Please contact our technical consultants.

# Height adjustable unit

Controllable measurement  
point displacement **HFM 5**  
Technical information /  
Instruction Manual



## Introduction / Function

### Introduction

The purpose of the device is to measure the level limit, by heightsetting adjustment, which enables simple setting of the desired switching point of the measuring probe.

### Function

A level limit switch can be inserted into and withdrawn from a container by means of a motor. A cog belt converts the rotational movement of the motor into linear movement.

The slide unit with the level limit switch moves up and down the guide shaft. The end position switches serve as stops. A 10-way precision-potentiometer is connected to the motor shaft via a slip clutch. The potentiometer setting shows a measurement for the momentary height of the level limit switch.

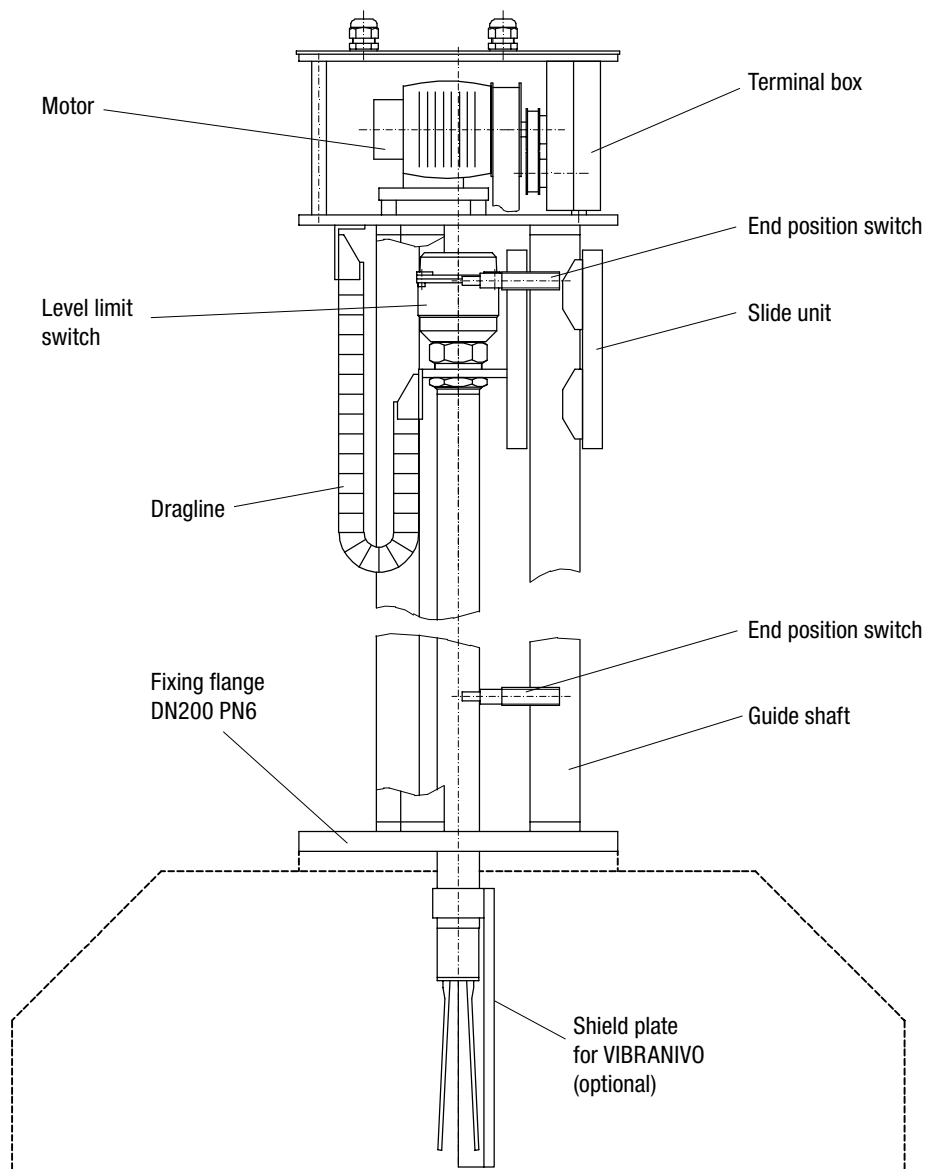

# Height adjustable unit

Controllable measurement  
point displacement **HFM 5**  
Technical information /  
Instruction manual



## Technical data

### Mechanical data

Dimensions:	see dimension sheet
Materials:	Base plate, support columns: Galvanised steel / VA Protective cover: Aluminium
Protection:	Motor: IP 44 Motor-terminal box: IP 54 Terminal box: IP 54 Grommet for Conduit-flange: IP 50
Weight:	approx. 90kg
Device mounting:	Flange for direct mounting on container (see dimension sheet)
Installation:	vertical
Displacement:	max. 2500 mm
Housing:	under protective cover

### Electrical data

Motor spec.:	Type: Three phase asynchronous motor nominal current (star): 3 x 0.7A nom. current (delta): 3 x 1.2A nominal voltage (star): 3 x 400V nominal volt. (delta): 3 x 230V +10% -15%
Nominal apparent power:	0.25kW
Elect. connection:	from motor terminal box onwards by means of cable glands and cable lugs
Wiring diagram:	Terminal box lid interior and documentation

### Sequencing data

Motor sequencing is carried out at factory.	
Slide unit:	Running speed while moving up or down: 4.7m/min Slide unit run-on after motor stops: approx. 15mm
Precision Potentiometer:	10-way, 1k $\Omega$ Linearity $\pm 0.25\%$ Tolerance $\pm 5\%$ Number of revolutions over whole setting height: 8 - 9.5
Resistance logic:	see wiring diagram
Level limit switch accuracy:	approx. 20 mm (depending on the process and bulk good)

**Note 1:** The potentiometer is situated in the terminal box and is connected to the motor shaft via a slip clutch. That way it cannot be damaged by the rotary movement of the motor.

**Note 2:** The potentiometer can be turned by hand at end stop when the slide unit has reached an end limit in order to retain a defined setting.

**Note 3:** While covering the adjustable height the potentiometer does not run through the whole resistance range. If this should cause control problems, please contact UWT.

### Operating conditions

Ambient temperature:	-10°C .. +55°C
Storage temperature:	-25°C .. +55°C
Air humidity:	95% max.
Container pressure:	not rated

## Technical data

### Level limit switch

**Vibrativo VN 2030** or **Rotonivo RN 3002**  
(for selection, see page P5) (for selection, see page P6)

#### Electrical connection:

From terminal box IP 55, aluminium housing,  
with M20 x 1.5 union - see wiring diagram.

### End switch

#### IG 0006 (ind. proximity switch)

Manufacturer: IFM  
Switching distance: 8 mm, not flush  
Connection voltage: 20-250V AC/DC all mains  
Signal output: two-lead, open contact  
max. 250 mA duration

or

#### NJ 15+U1+E2 (ind. proximity switch)

Manufacturer: Pepperl und Fuchs  
Switching distance: 15 mm, flush  
Connection voltage: 1 0 - 30V DC  
Power consumption: approx. 20 mA  
Signal output: PNP, open contact  
max. 200 mA duration

or

#### 3 S E3 200-1E (mech. position switch)

Manufacturer: Siemens  
Signal output: 1u pot. free  
max. 250V, max. 6A

or

#### IG 5401 (ind. proximity switch)

Manufacturer: IFM  
Switching distance: 8 mm, not flush  
Connection voltage: 10 - 36V / DC  
Power consumption: approx. 15 mA  
Signal output: PNP, open contact  
max. 250 mA duration  
Elect. connection: from terminal box IP 55,  
aluminium housing, with  
2x M20 x 1.5 union - see  
wiring diagram

# Height adjustable unit

Controllable measurement  
point displacement **HFM 5**  
Technical information /  
Instruction manual



## Technical data

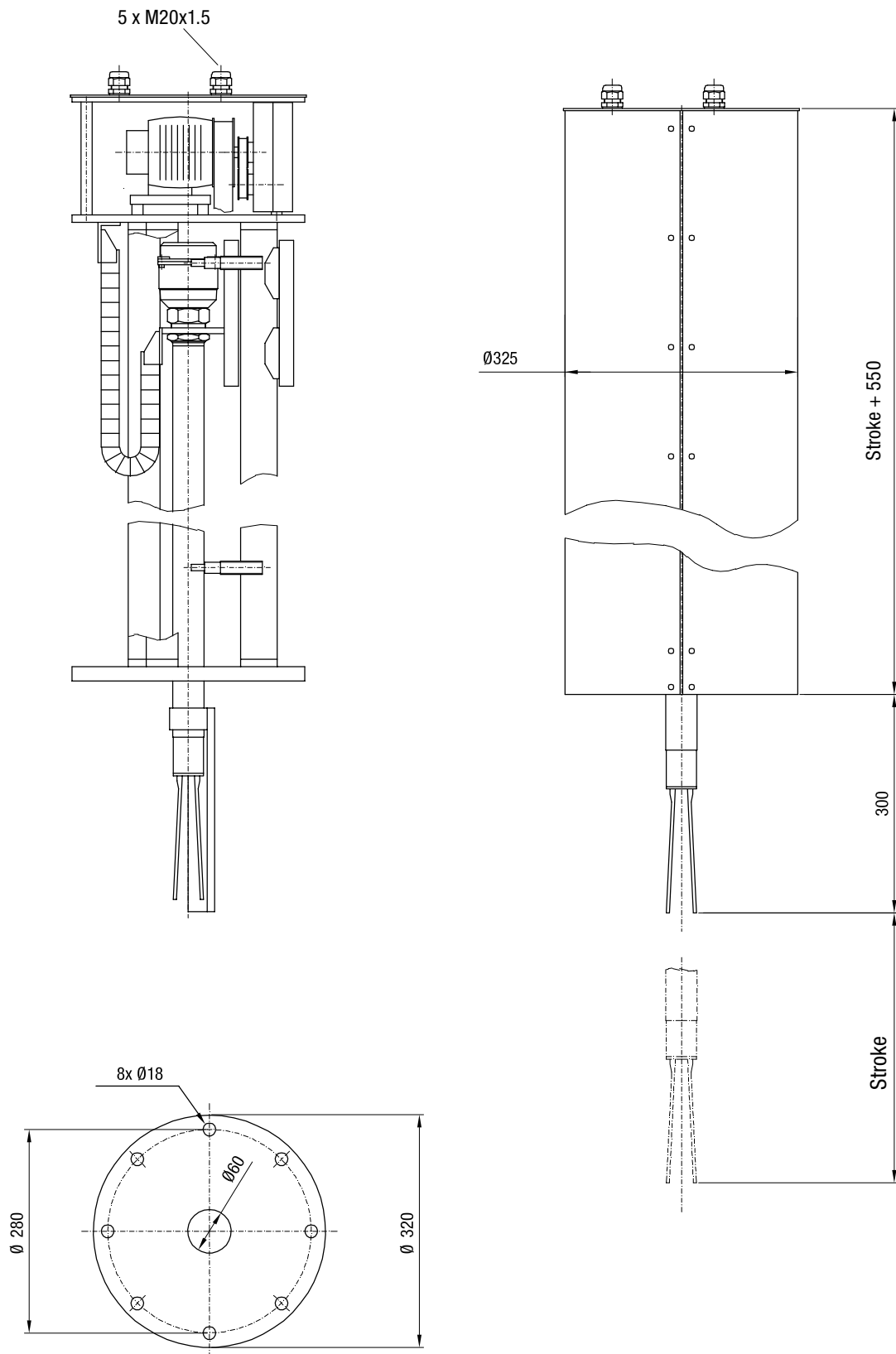

# Height adjustable unit

Controllable measurement point displacement **HFM 5**  
 Technical information /  
 Instruction Manual



## Electrical connection

Height adjustable unit HFM 5

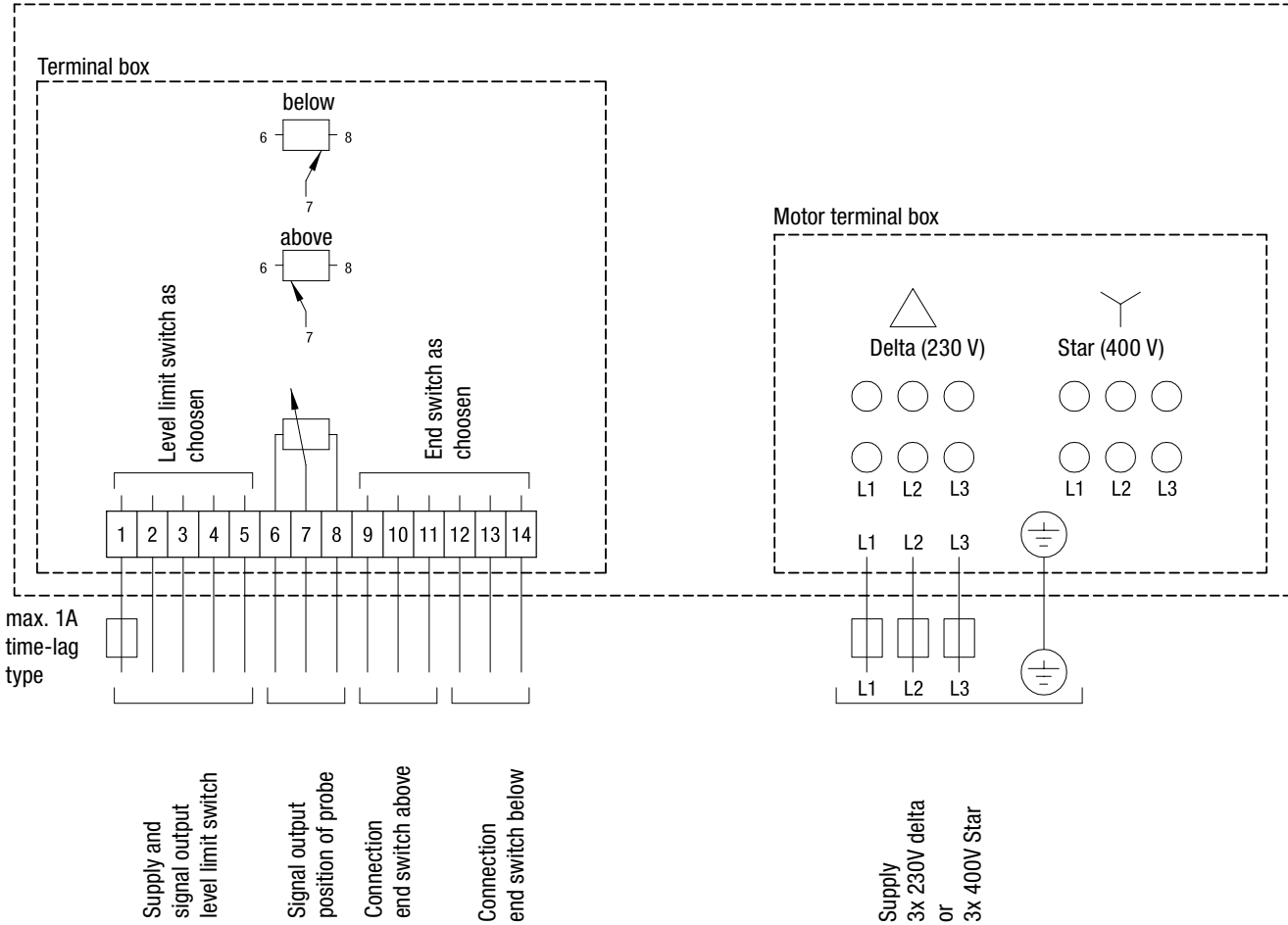

## Mounting

Secure device to flange vertically.

### Safety note

Ensure that device is secured in a perfectly stable position.

## Electrical connection

For electrical connections to terminal box and motor terminal box see wiring diagram.

Motor connection in motor terminal box according to wiring diagram, delta or star.

When connecting inductive loads to the end switches or signal output of the level limit switch, take into account suppress interference procedures.

### Safety notes

Ensure that emergency automatic cut-off is installed according to EN 60240-1 chapter 6.3.1 as protection against indirect contact with dangerous voltages.

In case of a situation as in EN 60240-1 chapter 10.7.1, an emergency cut-off (see chapter 10.7) must be installed.

Electrical supply must be protected against power surges, as in wiring diagram and according to EN 60240-1 chapter 7.2.

The device must be connected to a power cut-off system which disconnects the power to all main components, with the exception of the nullator, to allow for maintenance work, etc.

See EN 60240-1 chapters 5.3 and 5.4 and machine guidelines appendix 1, point 1.2.4 (main switch).

If the level limit switch signal circuit or end switch carries possibly damaging voltages, these must be disconnected along with the main switch.

Control installation must follow EN 60240-1 chapter 9. In this respect, ensure that when the end switch is reached, the motor switches off immediately, to avoid mechanical over-run of the slide unit.

## Putting into operation

### Safety notes

Parts of the body can get trapped by the moving slide unit.

**Operation must not begin unless the protective cover supplied is properly bolted down.**

## Maintenance

After running up and down for about 100 hours, check the cog belt for wear and tension.

Check level limit switch for mechanical wear and damage, according to frequency of use.

### Safety notes

Before starting any maintenance work, the power supply to all main parts and signal circuit of the limit level switch and end switch (if this should carry possibly damaging voltage) must be disconnected and measures must be taken to prevent reconnection.

The terminal box and motor terminal box may only be opened with power disconnected.

# Height adjustable unit

Controllable measurement  
point displacement **HFM 5**  
Technical information /  
Instruction Manual



## Spare parts

---

Drive motor	Bauser DMK 8061, 230/400V, 50Hz 2650 rpm Drive SSG 14, 150:1
Cog belt	25 T 10
Slide unit bearing	6000 2RSR
Pulley block bearing	6002 2RSR
Potentiometer	69 E 416 10-way, 1k $\Omega$
Felt strip	5 x 6, approx. 150 mm long