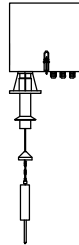

Table of contents

	Page
Dimensions	P2
Selection / Option	P3

Spare parts	P4

Electrical installation	P5



Subject to technical and price change.

All dimensions in mm (inches).

All prices are EXW Betzigau, excl. packaging costs and VAT.

Prices are valid from 01.04.2011 until 31.03.2012 unless otherwise agreed.

By publishing this selection list all other lists become invalid.

Different variations to those specified are possible. Please contact our technical consultants.

We assume no liability for typing errors.

All units of this selection list are CE - certified.

Dimensions

Electromechanical measuring system for bulk goods

Protection class IP54, low maintenance, easy to service.

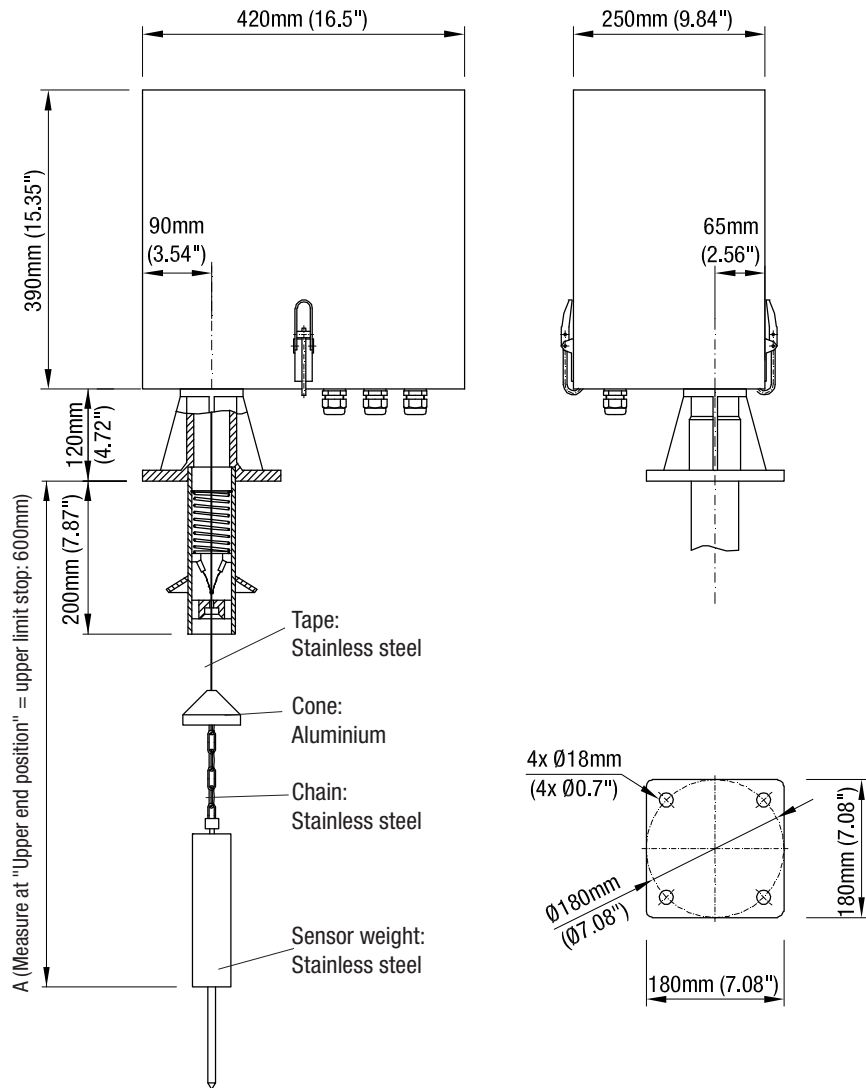

pos. 21
Mounting set Ø18

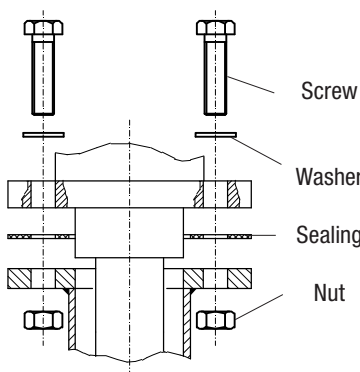

pos. 22
Mounting set M16

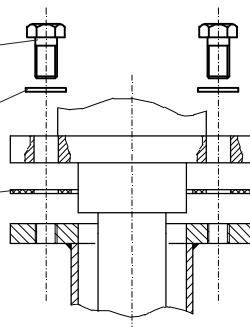

pos. 23
Weather protection cover
 (Aluminium)

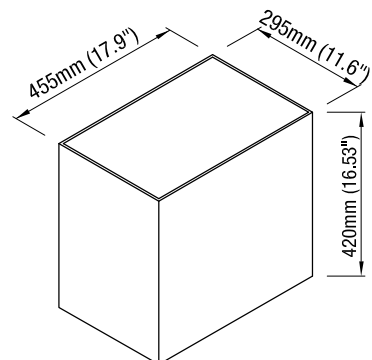

Spare parts

Spare parts

Loose tape	mf-va-012 x 0.2	loose tape (price per 1m)
Tape roller complete	sb110040 + mf-va-012 x 0.2 (30m)	tape roller with 30m tape
	sb110040 + mf-va-012 x 0.2 (50m)	tape roller with 50m tape
	sb110040 + mf-va-012 x 0.2 (70m)	tape roller with 70m tape
Sensor weight (delivery parts: see figure below)	sb100600	stainles steel 1.4301
	sb100620	folding cover 1.4301 / canvas

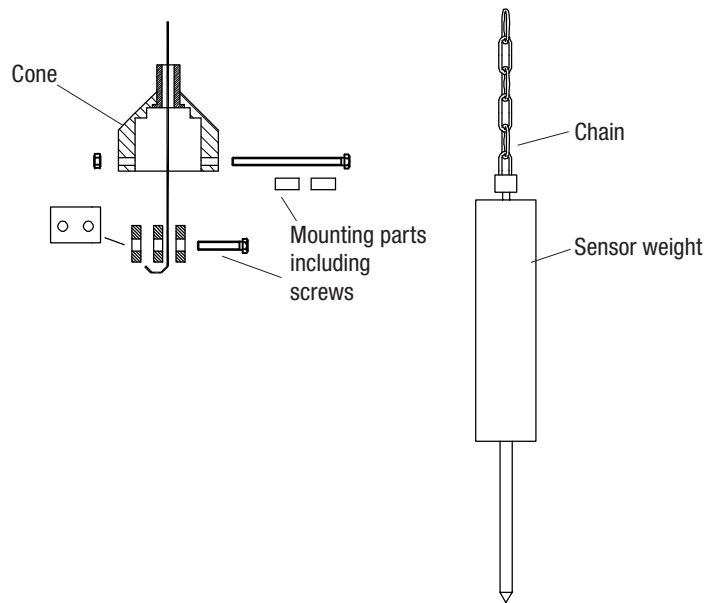

Electrical connection

