

Table of contents

	Page
Operation / overview	G2

Option / function	G3

Interfaces	G4

Interfaces / signal inputs digital - analogue	G5

Technical data / dimensions	G6

Components / installation / repairs / maintenance and care	G7

Technical information subject to change

Different variations to those specified are possible.

We assume no liability for printing errors

Please contact our technical staff

Operation / overview

Operation

The NT 1000 is a 5.7" touch panel for the fill level visualisation of silos and vessels. The applications can be in bulk solids as well as liquids. The touch panel functions with analogue 4-20mA signals, digital signals and the Nivowave sensor modbus RTU. It can either be installed in an existing control cabinet or delivered with a control cabinet. Once the power is connected, the NT 1000 automatically runs the visualisation start page. After entering the password, the necessary pages for programming can be accessed.

A clearly arranged manual is provided for operating the software which makes it easy to set all necessary signal inputs and silo parameters. The signal inputs can either be directly connected to the NT 1000 according to the wiring diagram or to the control cabinet according to the electrical plans, when the control cabinet is delivered with the NT 1000.

The NT 1000 is a complete system for easy fill level and trend displays. When the remote function is selected, it is possible to view and use the software via an Ethernet connected PC. This function also include an SD card on the touch panel which can be used for software updates.

All necessary settings including signal inputs and silo dimensions can be programmed in the software. The contents level can be calculated and displayed in height, volume, weight or percentage. Level limits are visible via light symbols on the respective vessel. It can also be defined whether the signal input should be linear or volume related, whether active digital inputs such as level switches are present or whether the Modbus RTU is being used by the Nivowave sensor. The software operating language is either German, English or French and is selected in the menu.

The Nivotec NT 1000 can be installed and set up by qualified electrical staff.

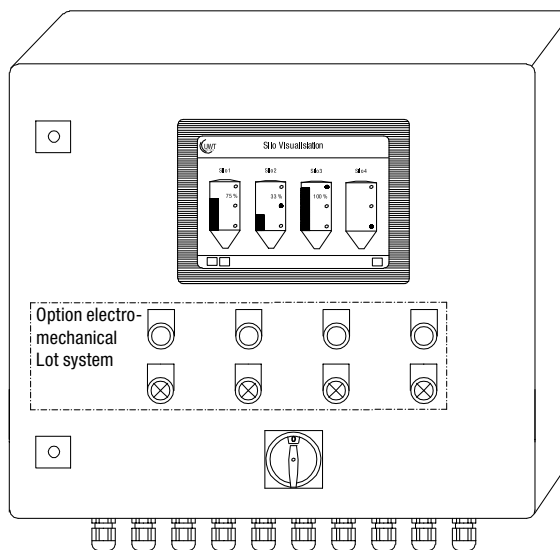

Equipment overview

System	Touch panel 5.7" with visualisations software for display of fill level and trend data from silos and vessels
Control cabinet	Deliverable complete with control cabinet or as an assembly unit. The supply voltage and fuses for the measurement technology is also included in the control cabinet.
Operation elements	When connected to the electromechanical Lot system, the necessary operating elements such as the start button, alarm signal, end signal can be installed in the control cabinet door.
Signal input	<ul style="list-style-type: none"> - Modbus RTU (Nivowave sensors) - up to 8 analogue inputs 4-20 mA - up to 14 digital inputs
Remote function	With this option it is possible to use and view the software on a PC via an Ethernet interface.

Option / function

Option	Function	
	Description	Additional information
Touchpanel	Operation of the touch panel is via the touch sensitive monitor surface. To use a particular function, touch the relevant area of the screen.	The software contains the following functions (details can be found in the separate software operating manual). <ul style="list-style-type: none"> - Processing of the input signal into a visual fill level display - Display of up to 6 silos on one page - Number of silos can be increased in the software - Clear and easy entry of all necessary signal input and silo parameters - Fill level display can be set in height, volume, weight and percentage - Trend monitoring
Control cabinet	Control cabinet for mounting on the wall with right hinged door.	The type and dimensions are dependant on the size of the project.
	Main switch is in the control cabinet door	
	Cable glands on the underside of the control cabinet	The number is dependant on the size of the project.
	All clamps for the connection of measurement signals, sensor and control cabinet power supplies, earthing etc are supplied in the control cabinet.	The control cabinet runs on 230 VAC. All further modules such as the power supplies, fuses, relays, logic modules, etc are in the cabinet on DIN rails and are internally wired.
	Project specific electric plans	The electric plans are prepared to the actual standards and contain all circuit diagrams, cable lists, clamp plans, parts lists and documentation of all components that are contained in the project.
Control cabinet with operating elements for the electromechanical lot system	Operating elements for the electromechanical lot system (start button, alarm signal LED, end position LED):	A measurement is started after pressing the start button. The green start button is illuminated during the measurement. Once the measurement is finished, the light is extinguished. The alarm signal LED is connected to the Lot system alarm relay and lights up when there is an interruption to the Lot.
Remote	The visualisation can be used by PC with an Ethernet interface.	This option contains a memory card in the NT 1000, which enables to make a software update.

Interfaces

Interfaces

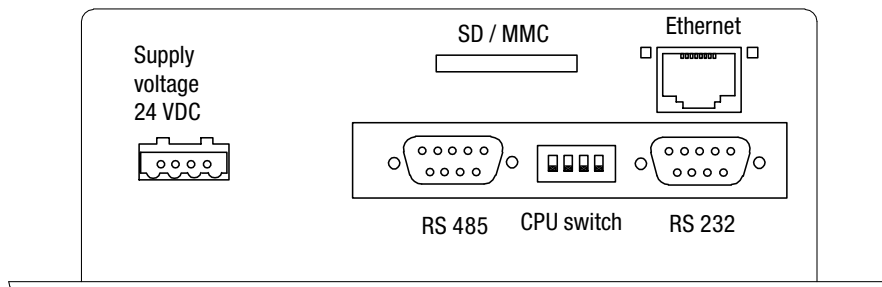

Supply voltage 24 VDC

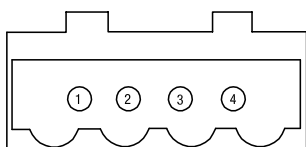

- PIN 1: 24 VDC
- PIN 2: not connected
- PIN 3: GND
- PIN 4: PE

Interface RS 232 (Sub D-plug)

This interface is reserved for the UWT technicians. This allows direct access to the software programming

Interface RS 485 (Sub D-plug)

The Nivowave modbus network is connected to this interface.

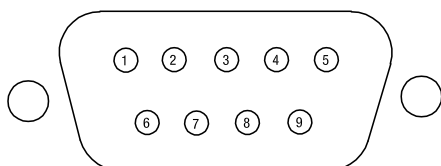

- PIN 1 to PIN 5 not used
- PIN 6: Modbus + / Nivowave clamp A (white)
- PIN 7: external bridge with PIN 6
- PIN 8: Modbus - / Nivowave clamp B (blue)
- PIN 9: external bridging with PIN 8

Remote function option

Interface Ethernet (RJ 45)

Connection to an Ethernet network is via an RJ 45 connector. It is recommended to use a CAT.5 cable for connection to the network.

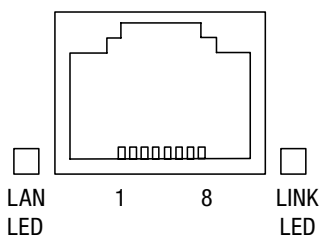

- | | |
|----------------------|----------------------|
| PIN 1: TD + | PIN 5: not connected |
| PIN 2: TD - | PIN 6: RD - |
| PIN 3: RD + | PIN 7: not connected |
| PIN 4: not connected | PIN 8: not connected |

The status of the connection is shown via 2 LEDs:
 LAN LED: Data is being sent / received
 LINK LED: Physical connection has been established

Interfaces / signal input digital analogue

SD card interface

An update of the software is possible with the SD card, which is supplied built in with the option remote function.

CPU switch

All switches must be turned off for the touch panel function. Further functions are the responsibility of the UWT technicians.

Signal input digital - analogue

Plug with with spring closing technology. Wiring protection for max 1.5mm²

Rear side view of housing.

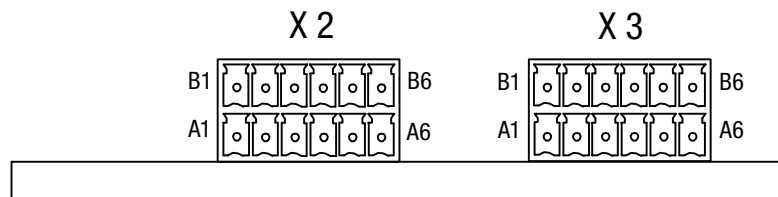

Digital input

Nominal value	24 VDC
High signal	15 - 30 VDC (nominal value 24 VDC) 3,5 - 10 mA (nominal value 5.5 mA)
Low signal	max. 5 VDC max. 1 mA
Optical isolation	500 VRMS (1 min)
Logic function	0 / 1

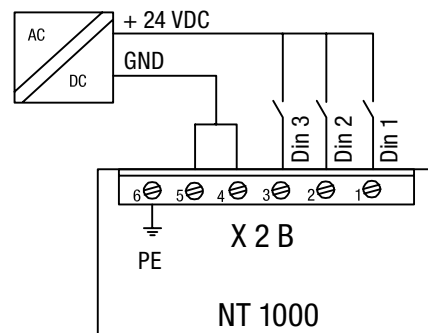
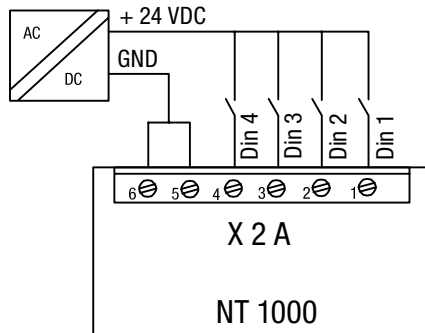

Analogue input

4...20 mA aktive, measurement accuracy: $\pm 0,5\%$ of measurement value; $R_{in} = 124 \text{ Ohm}$

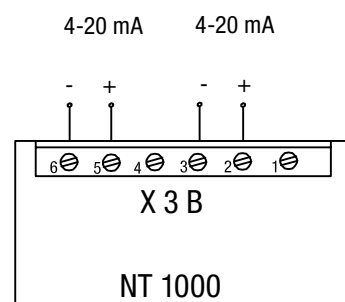
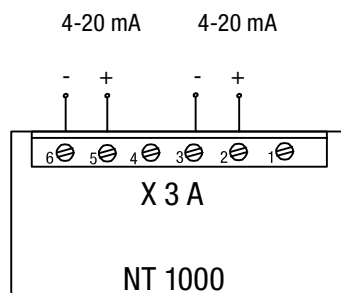

Technical data / dimensions

Display	Size	5,7"
	Display technique	TFT
	Colour	65.536
	Display area	115 x 86 mm
	Resolution (Pixels)	320 x 240
Touch	Technology	analogue resistance touch foil
Supply voltage (NT 1000 as assembly module)	Input voltage	24 VDC +-20%
	Current drain	max. 450 mA;
	Operational current drain	250 mA
	Power drain	6.0 W
	Fuse	Microfuse 5 mm x 20 mm, 2 A medium time lag
Supply voltage (NT 1000 with control cabinet)	By selection of a control cabinet the supply voltage and current drain is dependant on the number of measurement points and the type and number of sensors	
Interfaces	To the measurement tech. / PC	RS 232, RS 485
	Transfer rate	4.8 - 115.2 kBit/s
	Optional	Ethernet
Hardware	Processor	32 bit - RISC - CPU
	Processor frequency	25 MHz
	Memory	2 MB
Operating conditions	Operating temperature	0 bis 50 °C
	Storage temperature	-10 bis 60 °C
	Protection class	IP 65 front, after installation
		IP 20 (rear housing)
Housing	Material	Electroplated metal housing
	Weight	1 kg

Dimensions

Front plate 202 x 152 mm

Cut-out 183 x 137 mm

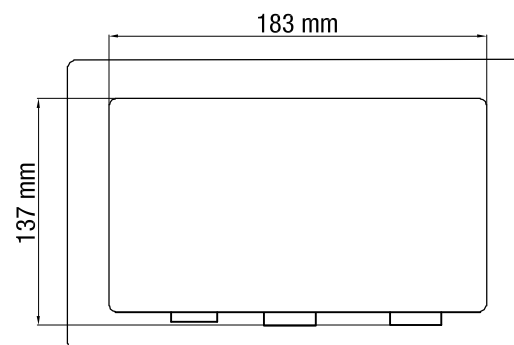
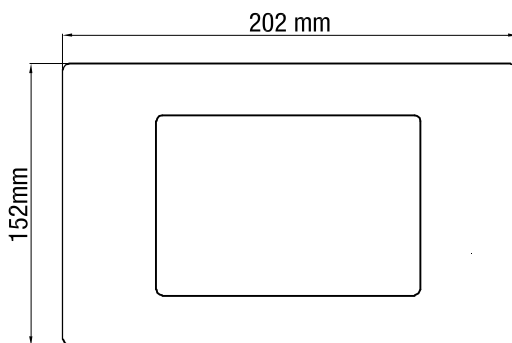

Installation depth 60 mm

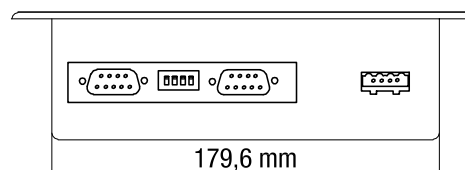
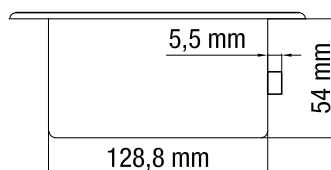

Components / installation / repairs / maintenance and care

Components

The component numbers correspond to the provided labelling on the control cabinet drawing.

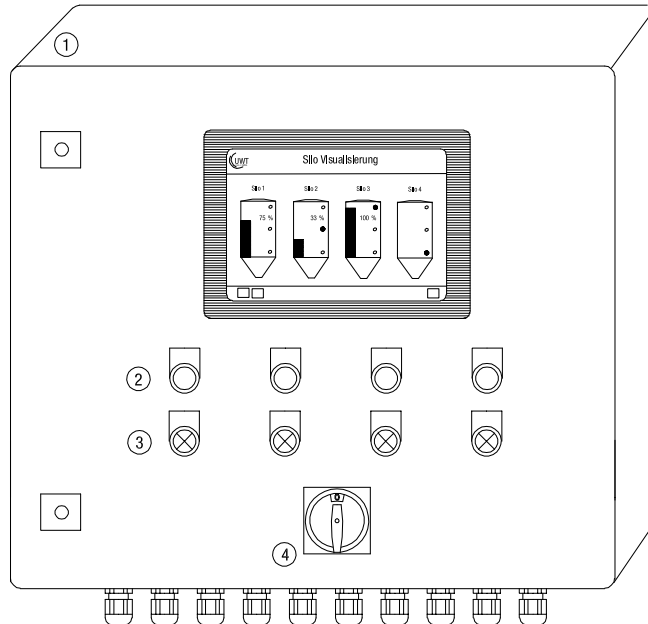

Nr.	Group	Labeling	Component
1	Housing	without	Rittal AE od Häwa, with right hinged swing door, RAL 7035
2	Start button for the electromechanical Lot system	START	Green colour, illuminates for the end signal
3	Alarm display for the electromechanical Lot system	Alarm	Red LED
4	Main switch	without	Type Moeller, red/green colour
	All displays		LEDs, TYP Moeller
	All buttons Taster		Type Moeller
	Clamps		Type Wago
	Fuse		Type ABB
	FI Switch		Type ABB
	Relays		Type SHC / Schrack
	Touch panel		Type Christ

Installation

- A flat and clean surface as well as the correct cut out aperture and sealing of the touch panel is a requirement to ensure protection class IP 65.
- All 5 mounting clamps must be mounted
- Pay attention to the angle of the installation (max. 40 °).

Repairs

- Repairs are only allowed to be carried out by qualified persons. Improper repairs can result in serious danger to the user.

Maintenance and care

- The touch panel must be disconnected from the power supply before cleaning.
- The touch sensitive surface must not be cleaned with solvents or corrosive substances.
- Use a damp soft cloth with mild soapy water for cleaning.w